



# OPA541

## High Power Monolithic OPERATIONAL AMPLIFIER

### FEATURES

- POWER SUPPLIES TO  $\pm 40V$
- OUTPUT CURRENT TO 10A PEAK
- PROGRAMMABLE CURRENT LIMIT
- INDUSTRY-STANDARD PIN OUT
- FET INPUT
- TO-3 AND LOW-COST POWER PLASTIC PACKAGES

### APPLICATIONS

- MOTOR DRIVER
- SERVO AMPLIFIER
- SYNCHRO EXCITATION
- AUDIO AMPLIFIER
- PROGRAMMABLE POWER SUPPLY

### DESCRIPTION

The OPA541 is a power operational amplifier capable of operation from power supplies up to  $\pm 40V$  and delivering continuous output currents up to 5A. Internal current limit circuitry can be user-programmed with a single external resistor, protecting the amplifier and load from fault conditions. The OPA541 is fabricated using a proprietary bipolar/FET process.

Pinout is compatible with popular hybrid power amplifiers such as the OPA511, OPA512 and the 3573.

The OPA541 uses a single current-limit resistor to set both the positive and negative current limits. Applications currently using hybrid power amplifiers requiring two current-limit resistors need not be modified.

The OPA541 is available in an 11-pin power plastic package and an industry-standard 8-pin TO-3 hermetic package. The power plastic package has a copper-lead frame to maximize heat transfer. The TO-3 package is isolated from all circuitry, allowing it to be mounted directly to a heat sink without special insulators.

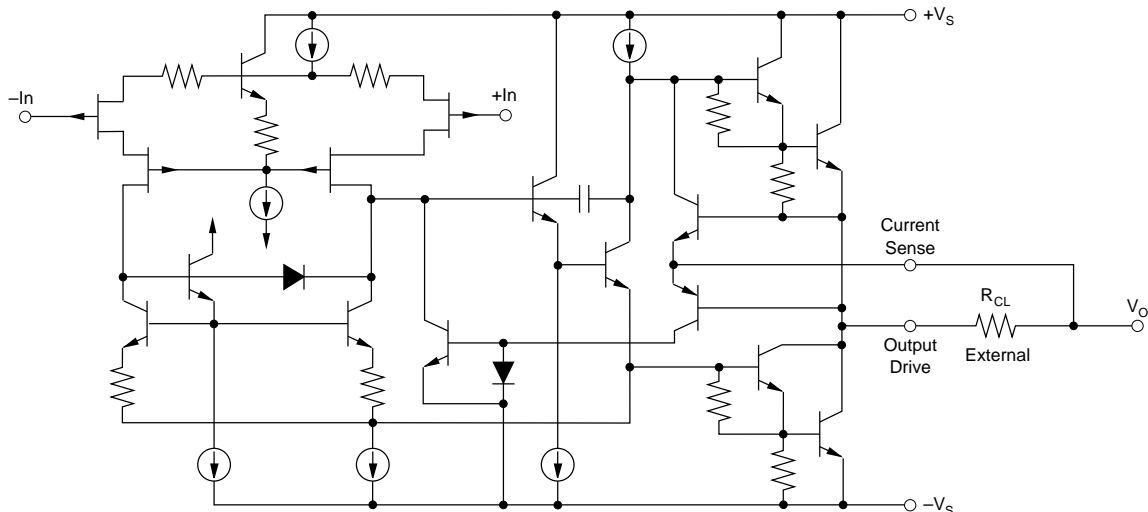

International Airport Industrial Park • Mailing Address: PO Box 11400 • Tucson, AZ 85734 • Street Address: 6730 S. Tucson Blvd. • Tucson, AZ 85706  
Tel: (520) 746-1111 • Twx: 910-952-1111 • Cable: BBRCORP • Telex: 066-6491 • FAX: (520) 889-1510 • Immediate Product Info: (800) 548-6132

# SPECIFICATIONS

## ELECTRICAL

At  $T_C = +25^\circ\text{C}$  and  $V_S = \pm 35\text{VDC}$  unless otherwise noted.

PARAMETER	CONDITIONS	OPA541AM/AP			OPA541BM/SM			UNITS
		MIN	TYP	MAX	MIN	TYP	MAX	
<b>INPUT OFFSET VOLTAGE</b> $V_{OS}$ vs Temperature vs Supply Voltage vs Power	Specified Temperature Range $V_S = \pm 10\text{V to } \pm V_{MAX}$		$\pm 2$ $\pm 20$ $\pm 2.5$ $\pm 20$	$\pm 10$ $\pm 40$ $\pm 10$ $\pm 60$		$\pm 0.1$ $\pm 15$ *	$\pm 1$ $\pm 30$ *	mV $\mu\text{V}/^\circ\text{C}$ $\mu\text{V/V}$ $\mu\text{V/W}$
<b>INPUT BIAS CURRENT</b> $I_B$			4	50		*	*	pA
<b>INPUT OFFSET CURRENT</b> $I_{OS}$	Specified Temperature Range		$\pm 1$	$\pm 30$ 5		*	*	pA nA
<b>INPUT CHARACTERISTICS</b> Common-Mode Voltage Range Common-Mode Rejection Input Capacitance Input Impedance, DC	Specified Temperature Range $V_{CM} = (\pm V_S) - 6\text{V}$	$\pm( V_S  - 6)$ 95	$\pm( V_S  - 3)$ 113 5 1		*	*		V dB pF T $\Omega$
<b>GAIN CHARACTERISTICS</b> Open Loop Gain at 10Hz Gain-Bandwidth Product	$R_L = 6\Omega$	90	97 1.6		*	*		dB MHz
<b>OUTPUT</b> Voltage Swing  Current, Peak	$I_O = 5\text{A, Continuous}$ $I_O = 2\text{A}$ $I_O = 0.5\text{A}$	$\pm( V_S  - 5.5)$ $\pm( V_S  - 4.5)$ $\pm( V_S  - 4)$ 9	$\pm( V_S  - 4.5)$ $\pm( V_S  - 3.6)$ $\pm( V_S  - 3.2)$ 10		*	*		V V V A
<b>AC PERFORMANCE</b> Slew Rate Power Bandwidth Settling Time to 0.1% Capacitive Load  Phase Margin	$R_L = 8\Omega, V_O = 20\text{Vrms}$ 2V Step Specified Temperature Range, $G = 1$ Specified Temperature Range, $G > 10$ Specified Temperature Range, $R_L = 8\Omega$	6 45 3.3	10 55 2 40		*	*	*	V/ $\mu\text{s}$ kHz $\mu\text{s}$ nF Degrees
<b>POWER SUPPLY</b> Power Supply Voltage, $\pm V_S$ Current, Quiescent	Specified Temperature Range	$\pm 10$	$\pm 30$ 20	$\pm 35$ 25	*	$\pm 35$ *	$\pm 40$ *	V mA
<b>THERMAL RESISTANCE</b> $\theta_{JC}$ (Junction-to-Case) <sup>(2)</sup> $\theta_{JC}$ <sup>(2)</sup> $\theta_{JA}$ (Junction-to-Ambient) OPA541AP (Plastic)	AC Output $f > 60\text{Hz}$ DC Output No Heat Sink		2.5 3 40 40					$^\circ\text{C/W}$ $^\circ\text{C/W}$ $^\circ\text{C/W}$ $^\circ\text{C/W}$
<b>TEMPERATURE RANGE</b> $T_{CASE}$	AM, BM, AP SM	-25		+85	*		*	$^\circ\text{C}$ $^\circ\text{C}$

\* Specification same as OPA541AM/AP.

NOTE: (1) SOA is the Safe Operating Area shown in Figure 1. (2) Plastic package may require insulator which typically adds  $1^\circ\text{C/W}$ .

The information provided herein is believed to be reliable; however, BURR-BROWN assumes no responsibility for inaccuracies or omissions. BURR-BROWN assumes no responsibility for the use of this information, and all use of such information shall be entirely at the user's own risk. Prices and specifications are subject to change without notice. No patent rights or licenses to any of the circuits described herein are implied or granted to any third party. BURR-BROWN does not authorize or warrant any BURR-BROWN product for use in life support devices and/or systems.

## DICE INFORMATION

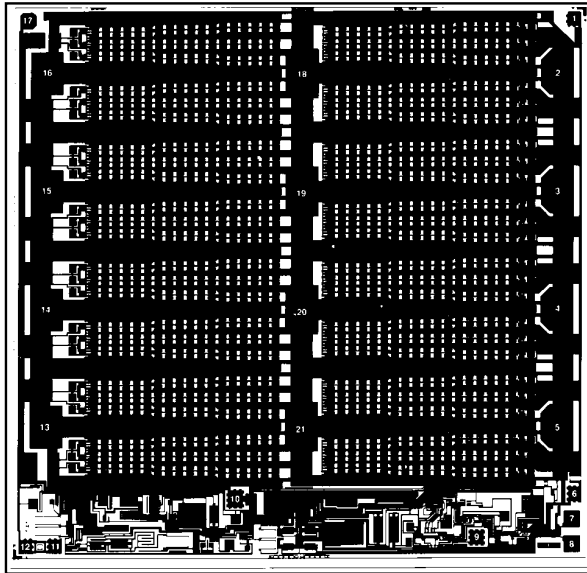

OPA541 DIE TOPOGRAPHY

PAD	FUNCTION	PAD	FUNCTION
1	NC	11	NC
2	-V <sub>S</sub>	12	Current Sense
3	-V <sub>S</sub>	13	+V <sub>S</sub>
4	-V <sub>S</sub>	14	+V <sub>S</sub>
5	-V <sub>S</sub>	15	+V <sub>S</sub>
6	NC	16	+V <sub>S</sub>
7	-In	17	Current Sense
8	+In	18	Output Drive
9	NC	19	Output Drive
10	NC	20	Output Drive
		21	Output Drive

NOTE: For full output current capability, wire-bond all like connections of +V<sub>S</sub>, -V<sub>S</sub> and Output Drive.

**Substrate Bias:** Electrically connected to -V<sub>S</sub> supply.

## MECHANICAL INFORMATION

	MILS (0.001")	MILLIMETERS
Die Size	213 x 205 ±5	5.41 x 5.21 ±0.13
Die Thickness	20 ±3	0.51 ±0.08
Min. Pad Size	4 x 4	0.1 x 0.1
Backing	Chromium-Silver	

## CONNECTION DIAGRAMS

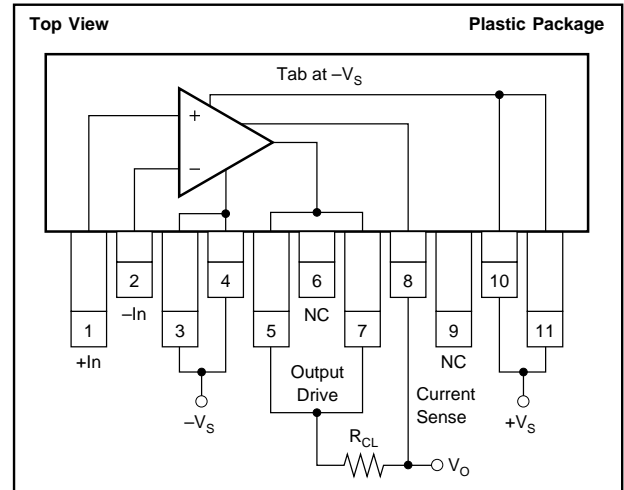
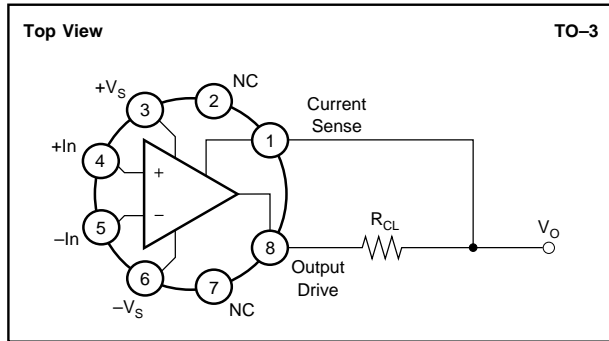

## ABSOLUTE MAXIMUM RATINGS

Supply Voltage, +V <sub>S</sub> to -V <sub>S</sub> .....	80V
Output Current .....	see SOA
Power Dissipation, Internal <sup>(1)</sup> .....	125W
Input Voltage: Differential .....	±V <sub>S</sub>
Common-mode .....	±V <sub>S</sub>
Temperature: Pin solder, 10s .....	+300°C
Junction <sup>(1)</sup> .....	+150°C
Temperature Range:	
AM, BM SM	
Storage .....	-65°C to +150°C
Operating (case) .....	-55°C to +125°C
AP	
Storage .....	-40°C to +85°C
Operating (case) .....	-25°C to +85°C

NOTE: (1) Long term operation at the maximum junction temperature will result in reduced product life. Derate internal power dissipation to achieve high MTTF.

## ORDERING INFORMATION

MODEL	PACKAGE	TEMPERATURE RANGE	CONTINUOUS CURRENT
OPA541AP	Power Plastic	-25°C to +85°C	5A at 25°C
OPA541AM	TO-3	-25°C to +85°C	5A at 25°C
OPA541BM	TO-3	-25°C to +85°C	5A at 25°C
OPA541SM	TO-3	-55°C to +125°C	5A at 25°C

## PACKAGE INFORMATION

MODEL	PACKAGE	PACKAGE DRAWING NUMBER <sup>(1)</sup>
OPA541AP	Power Plastic	242
OPA541AM	TO-3	030
OPA541BM	TO-3	030
OPA541SM	TO-3	030

NOTE: (1) For detailed drawing and dimension table, please see end of data sheet, or Appendix D of Burr-Brown IC Data Book.

# TYPICAL PERFORMANCE CURVES

$T_A = +25^\circ\text{C}$ ,  $V_S = \pm 35\text{VDC}$  unless otherwise noted.

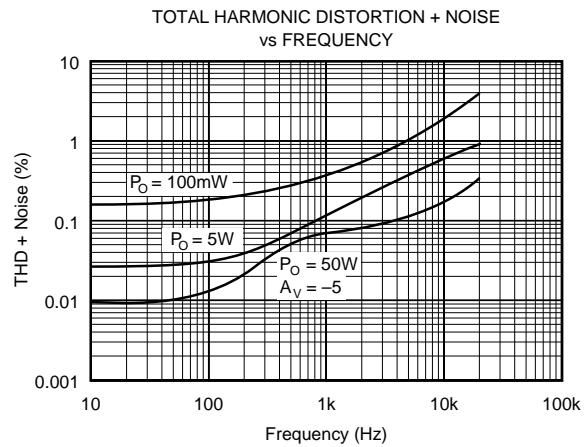
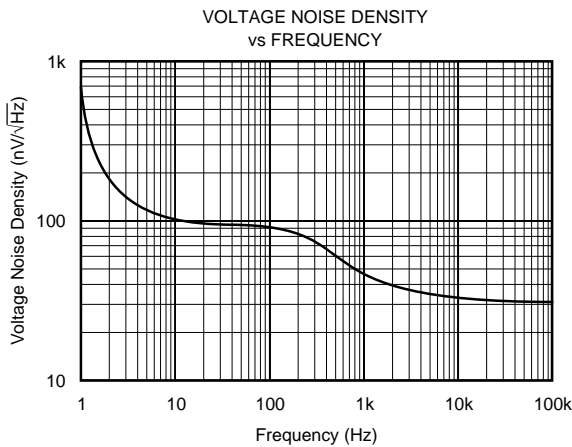
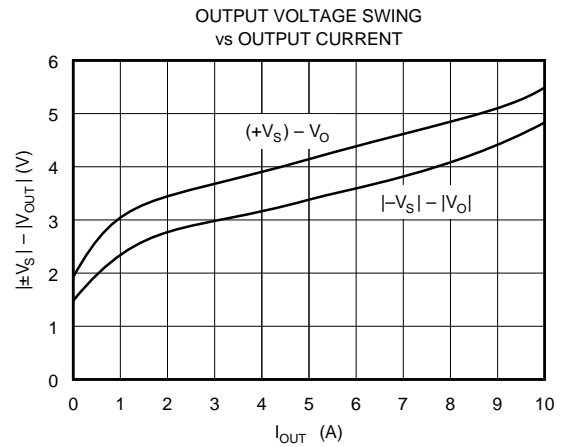
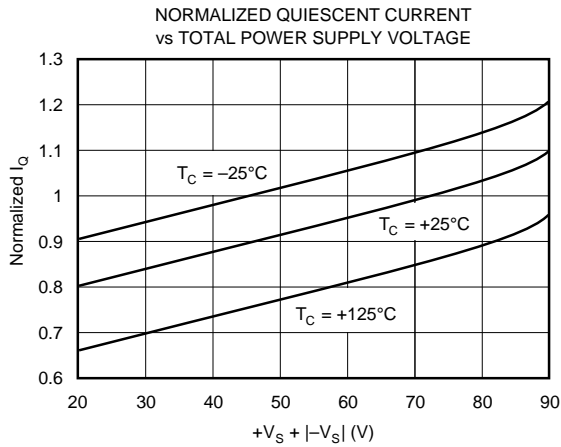
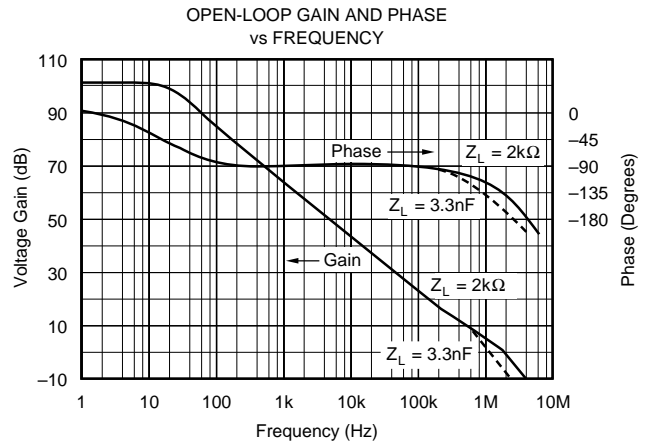
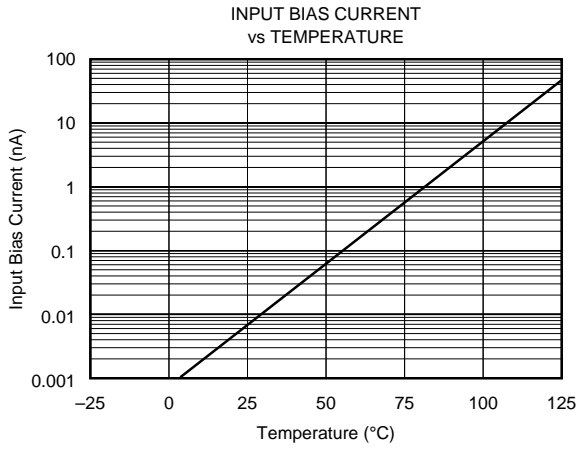

# TYPICAL PERFORMANCE CURVES (CONT)

$T_A = +25^\circ\text{C}$ ,  $V_S = \pm 35\text{VDC}$  unless otherwise noted.

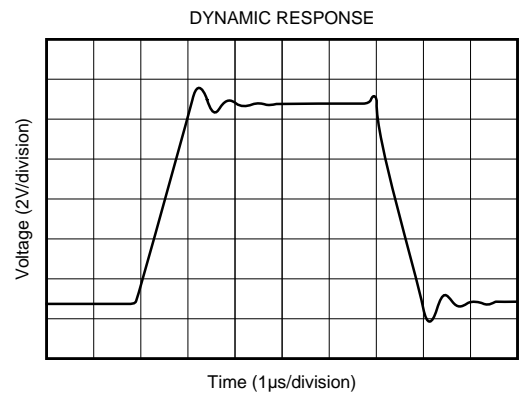
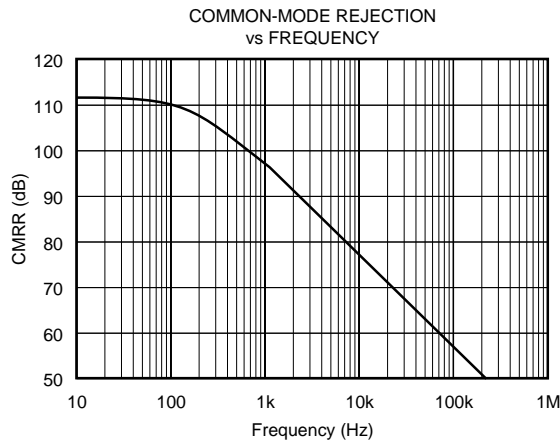
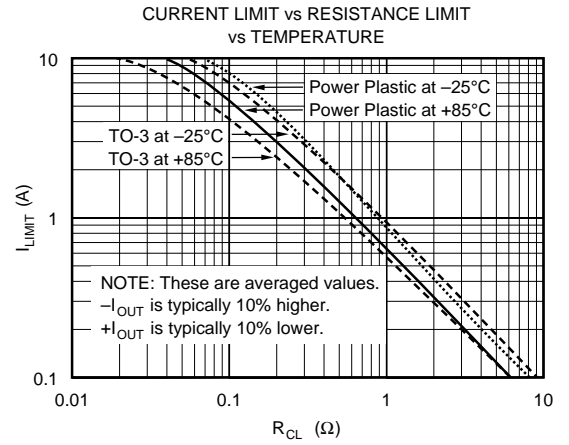
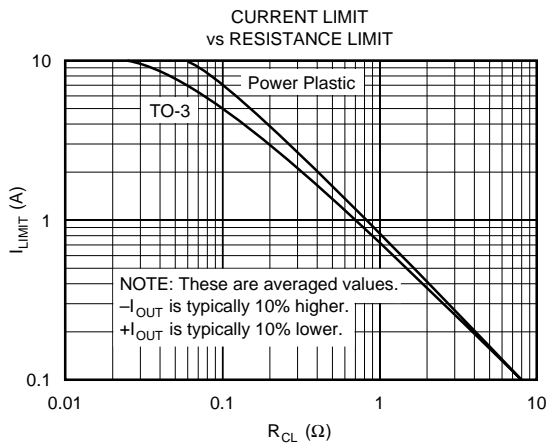

# INSTALLATION INSTRUCTIONS

## POWER SUPPLIES

The OPA541 is specified for operation from power supplies up to  $\pm 40\text{V}$ . It can also be operated from unbalanced power supplies or a single power supply, as long as the total power supply voltage does not exceed  $80\text{V}$ . The power supplies should be bypassed with low series impedance capacitors such as ceramic or tantalum. These should be located as near as practical to the amplifier's power supply pins. Good power amplifier circuit layout is, in general, like good high frequency layout. Consider the path of large power supply and output currents. Avoid routing these connections near low-level input circuitry to avoid waveform distortion and oscillations.

## CURRENT LIMIT

Internal current limit circuitry is controlled by a single external resistor,  $R_{CL}$ . Output load current flows through this external resistor. The current limit is activated when the voltage across this resistor is approximately a base-emitter turn-on voltage. The value of the current limit resistor is approximately:

$$\text{(AM, BM, SM)} \quad R_{CL} = \frac{0.809}{|I_{LIM}|} - 0.057$$

$$\text{(AP)} \quad R_{CL} = \frac{0.813}{|I_{LIM}|} - 0.02$$

Because of the internal structure of the OPA541, the actual current limit depends on whether current is positive or negative. The above  $R_{CL}$  gives an average value. For a given  $R_{CL}$ ,  $+I_{OUT}$  will actually be limited at about 10% below the expected level, while  $-I_{OUT}$  will be limited about 10% above the expected level.

The current limit value decreases with increasing temperature due to the temperature coefficient of a base-emitter junction voltage. Similarly, the current limit value increases at low temperatures. Current limit versus resistor value and temperature effects are shown in the Typical Performance Curves. Approximate values for  $R_{CL}$  at other temperatures may be calculated by adjusting  $R_{CL}$  as follows:

$$\Delta R_{CL} = \frac{-2\text{mV}}{|I_{LIM}|} \times (T - 25)$$

The adjustable current limit can be set to provide protection from short circuits. The safe short-circuit current depends on power supply voltage. See the discussion on Safe Operating Area to determine the proper current limit value.

Since the full load current flows through  $R_{CL}$ , it must be selected for sufficient power dissipation. For a 5A current limit on the TO-3 package, the formula yields an  $R_{CL}$  of  $0.105\Omega$  ( $0.143\Omega$  on the power plastic package due to different internal resistances). A continuous 5A through  $0.105\Omega$  would require an  $R_{CL}$  that can dissipate  $2.625\text{W}$ .

Sinusoidal outputs create dissipation according to rms load current. For the same  $R_{CL}$ , AC peaks would still be limited to 5A, but rms current would be  $3.5\text{A}$ , and a current limiting resistor with a lower power rating could be used. Some applications (such as voice amplification) are assured of signals with much lower duty cycles, allowing a current limiting resistor with a low power rating. Wire-wound resistors may be used for  $R_{CL}$ . Some wire-wound resistors, however, have excessive inductance and may cause loop-stability problems. Be sure to evaluate circuit performance with resistor type planned for production to assure proper circuit operation.

## HEAT SINKING

Power amplifiers are rated by case temperature, not ambient temperature as with signal op amps. Sufficient heat sinking must be provided to keep the case temperature within rated limits for the maximum ambient temperature and power dissipation. The thermal resistance of the heat sink required may be calculated by:

$$\theta_{HS} = \frac{T_{CASE} - T_{AMBIENT}}{P_D \text{ (max)}}$$

Commercially available heat sinks often specify their thermal resistance. These ratings are often suspect, however, since they depend greatly on the mounting environment and air flow conditions. Actual thermal performance should be verified by measurement of case temperature under the required load and environmental conditions.

No insulating hardware is required when using the TO-3 package. Since mica and other similar insulators typically add approximately  $0.7^\circ\text{C}/\text{W}$  thermal resistance, their elimination significantly improves thermal performance. See Burr-Brown Application Note AN-83 for further details on heat sinking. On the power plastic package, the metal tab is connected to  $-V_S$ , and appropriate actions should be taken when mounting on a heat sink or chassis.

## SAFE OPERATING AREA

The safe operating area (SOA) plot provides comprehensive information on the power handling abilities of the OPA541. It shows the allowable output current as a function of the voltage across the conducting output transistor (see Figure 1). This voltage is equal to the power supply voltage minus the output voltage. For example, as the amplifier output swings near the positive power supply voltage, the voltage across the output transistor decreases and the device can safely provide large output currents demanded by the load.

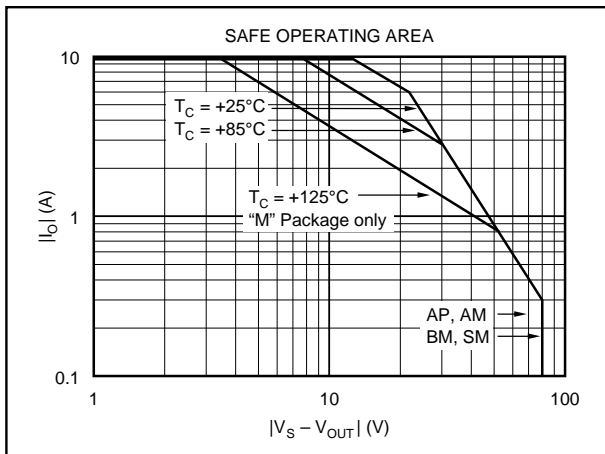

FIGURE 1. Safe Operating Area.

Short circuit protection requires evaluation of SOA. When the amplifier output is shorted to ground, the full power supply voltage is impressed across the conducting output transistor. The current limit must be set to a value which is safe for the power supply voltage used. For instance, with  $V_S \pm 35V$ , a short to ground would force 35V across the conducting power transistor. A current limit of 1.8A would be safe.

Reactive, or EMF-generating, loads such as DC motors can present difficult SOA requirements. With a purely reactive load, output voltage and load current are  $90^\circ$  out of phase. Thus, peak output current occurs when the output voltage is zero and the voltage across the conducting transistor is equal to the full power supply voltage. See Burr-Brown Application Note AN-123 for further information on evaluating SOA.

### REPLACING HYBRID POWER AMPLIFIERS

The OPA541 can be used in applications currently using various hybrid power amplifiers, including the OPA501, OPA511, OPA512, and 3573. Of course, the application must be evaluated to assure that the output capability and other performance attributes of the OPA541 meet the necessary requirement. These hybrid power amplifiers use two current limit resistors to independently set the positive and negative current limit value. Since the OPA541 uses only one current limit resistor to set both the positive and negative current limit, only one resistor (see Figure 4) need be installed. If installed, the resistor connected to pin 2 (TO-3 package) is superfluous, but it does no harm.

Because one resistor carries the current previously carried by two, the resistor may require a higher power rating. Minor adjustments may be required in the resistor value to achieve the same current limit value. Often, however, the change in current limit value when changing models is small compared to its variation over temperature. Many applications can use the same current limit resistor.

## APPLICATIONS CIRCUITS

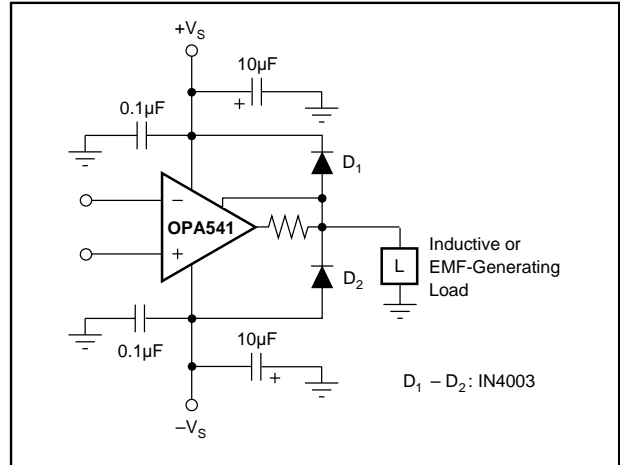

FIGURE 2. Clamping Output for EMF-Generating Loads.

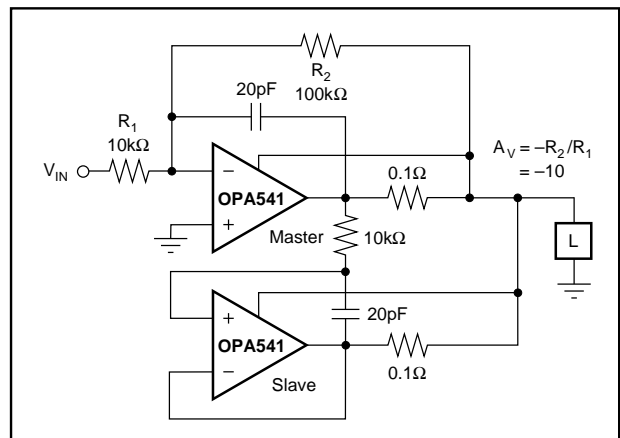

FIGURE 3. Isolating Capacitive Loads.

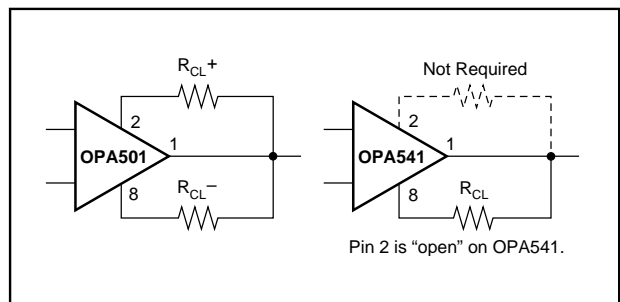

FIGURE 4. Replacing OPA501 with OPA541.

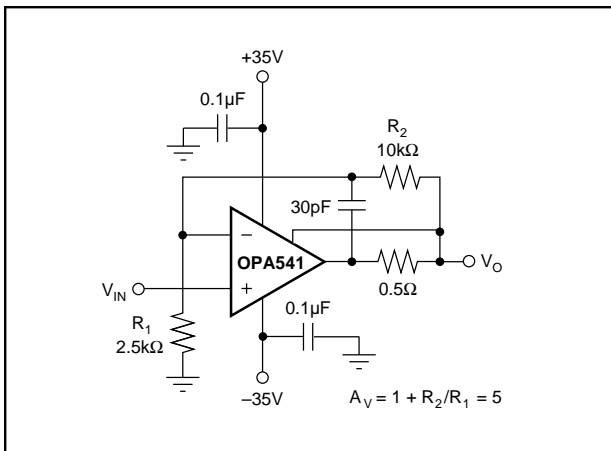

FIGURE 5. Paralleled Operation, Extended SOA.

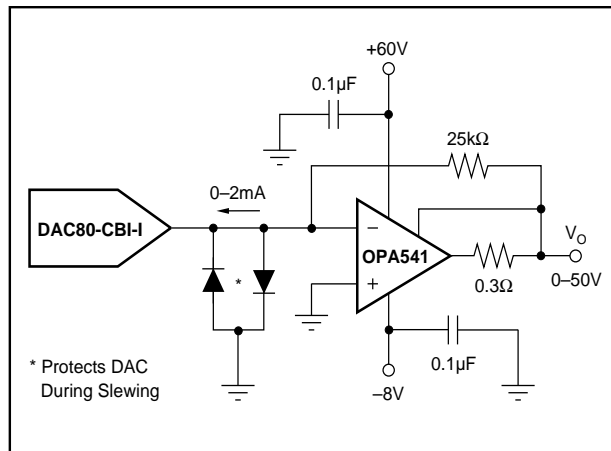

FIGURE 6. Programmable Voltage Source.

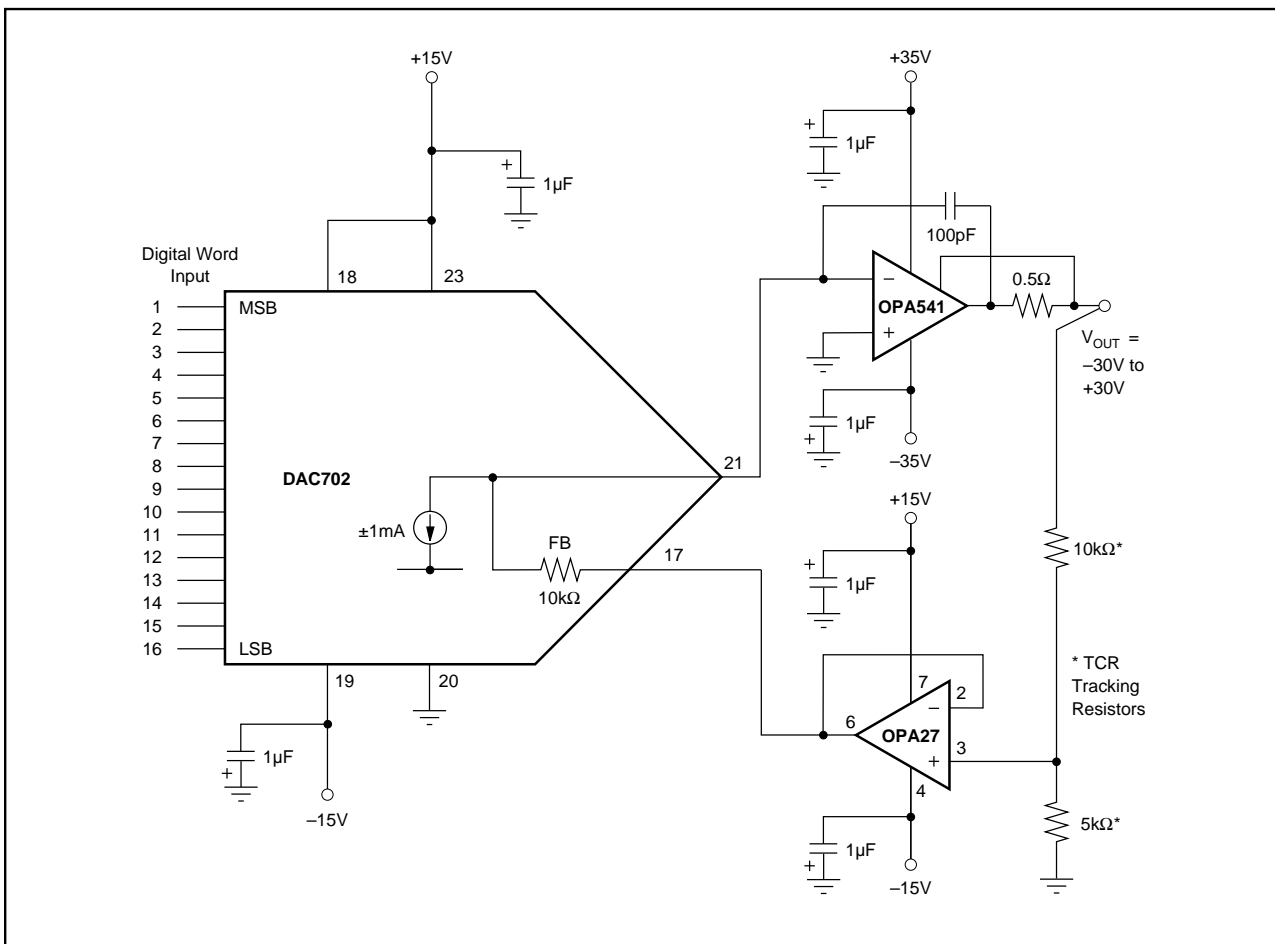

FIGURE 7. 16-Bit Programmable Voltage Source.